

NUMERICAL APPROACH TO A LOW PRESSURE GAS-INJECTION SCROLL COMPRESSOR

by

**Guang-Hui ZHOU, Hai-Jun LI^{*}, Lei LIU, Deng-Ke ZHAO,
Pan-Pan WEI, and Tong CHEN**

School of Energy & Environment, Zhongyuan University of Technology,
Zhengzhou, Henan, China

Original scientific paper
DOI: 10.2298/TSCI1504383Z

In order to solve problems arising in ordinary heat pump system for pure electric vehicles at ultra-low temperature, a low pressure gas-injection scroll compressor is designed, and a mathematical model is established. Comparison with the experimental results shows good accuracy of the theoretical prediction.

Key words: electric vehicles, gas-injection, scroll compressor, numerical

Introduction

Compared to the conventional cars, the pure electric vehicles (PEV) have incomparable advantages in terms of energy saving and environment protection. The replace traditional fuel engine with the motor leads to the power of cars changed, so it is particularly important to develop a suitable air-conditioning system for PEV. Currently, the compressor is driven by engine to achieve refrigeration in air conditioning for traditional fuel automotive, and it relies on the heat of the engine cooling water for heating and defrosting; however, the power of the PEV is a motor, there is no cooling water for heating during the winter months. It can only rely on the positive temperature coefficient, heat pump circulation system or other methods to realize heating. Considering problems that the capacity of PEV battery and the car trip range, high efficiency, energy saving have become the two major issues during the research of the PEV air conditioning system. Air source heat pump air conditioning system is easy to use, and it has high coefficient of performance (*COP*), it has been widely used in our daily life. When heat pump air conditioning system applied to PEV, problems we are facing is that the compressor discharge temperature become too high and the *COP* degrading seriously as the outside temperature gradually reduced in cold areas, thus limit the development of heat pump air conditioning system used in electric vehicles. To solve this problem, a low pressure gas-injection scroll compressor applied to heat pump for electric vehicles is designed, it can effectively solve problems that the low *COP* and the high discharge temperature of the compressor when system running at low temperature [1]. To the end, the mathematical model of low pressure gas-injection scroll compressor is built, and a comparative analysis between simulation results and experimental data is made.

^{*} Corresponding author; e-mail: haijun_li007@126.com

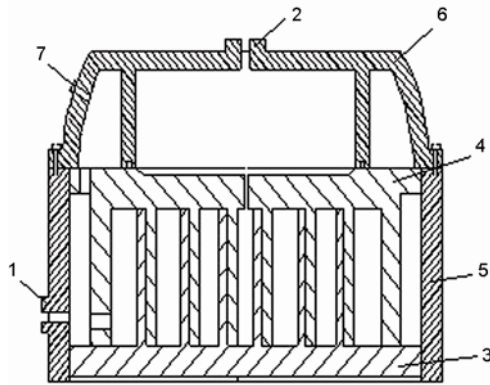

Figure 1. Gas-injection port structure for the scroll compressor

1 – air entry, 2 – air vent, 3 – dynamic eddy, 4 – static eddy, 5 – shell, 6 – shell cover, 7 – air supply

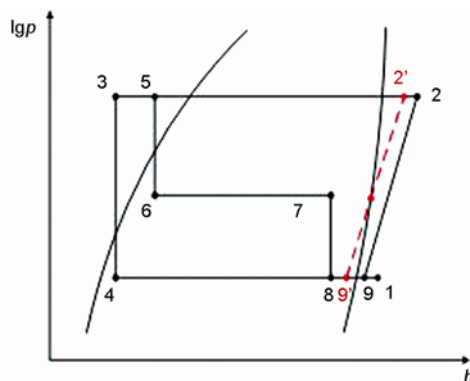

Figure 2. Log p - h diagram of the heat pump cycle with middle heat exchanger

Hence, the gas-injection hybrid process is actually unsteady and variable-mass [4].

Mathematical model of low pressure gas injection process

As mentioned, for the low pressure gas compression system, the process of gas injection can be taken as an adiabatic hybrid process, then the refrigerant was compressed by compressor after gas injection. The whole process can be divided into two stages, a general mathematical model of low pressure gas injection system suitable for scroll compressor is established.

Mixing stage of the compensation gas

Figure 2 shows that the refrigerant (state 8) which status is from the intermediate heat exchanger, flowing into the compressor working cavity, then mixing with the superheated gas (state 9) in the cavity, the mixing process can be considered as a process of isobaric enthalpy increasing. At this time, the status of the gas in working cavity changes from state 9

Low pressure gas-injection scroll compressor

The structure of a low pressure gas-injection scroll compressor is shown in fig. 1. Its working principle is a plurality of compression cavities form during the engagement and disengagement of the movable scroll and the stationary scroll [2]. At this time, the refrigerant gas from the intermediate heat exchanger is mixed with the overheating gas from the main road which through the outdoor heat exchanger of the vehicle in the low pressure side of the compressor's suction cavity, accordingly the low pressure gas injection process achieved. As opposed to the ordinary heat pump circulation system, the heating capacity has been improved by increasing the degree of super-cooling of the condenser; it can safely run in low temperature condition because we effectively reduce the compressor discharge temperature [3].

Compared with traditional heat pump circulation, the low pressure gas-injection heat pump air-conditioning system adds a hybrid process in compressor suction pocket. The process can be taken as an adiabatic-isobaric and enthalpy-increasing process due to the instantaneous process; the principle of thermodynamic cycle is shown in fig. 2. As a result of gas injection, mass flow rate of the refrigerant in compressor working cavity grows sustainably.

before gas injection to state 9' after gas injection, and the mass is increased from the original m_1 to m_3 , where m_1 [kgs⁻¹] is the mass flow rate of the refrigerant in the main inlet of the compressor, m_2 [kgs⁻¹] – the mass flow rate of the refrigerant in the auxiliary inlet of compressor, m_3 [kgs⁻¹] – the mass flow rate of the refrigerant after mixing, and h_9 , [Jkg⁻¹] – the average specific enthalpy of the refrigerant after mixing.

Consequently:

$$m_3 h_{9'} = m_1 h_8 + m_2 h_9 \quad (1)$$

$$h_{9'} = \frac{m_1 h_8 + m_2 h_9}{m_3} \quad (2)$$

$$T_{9'} = f(h_{9'}) \quad (3)$$

Interior compression after mixing

After gas injection, the compressor's working cavity is departed from auxiliary injections, gas inside the compressor relies on the reduction of primitive volume to be compressed, until the working cavity and discharge cavity are connected. It can be seen from the principle diagram of the heat pump circulation, the state of 9' is compressed to the state of 2', and we assume that it is an isentropic process. Because the scroll compressor belongs to the fixed volume ratio compressor, so when the compression cavity and the discharge cavity are interlinked, the discharge pressure in its working cavity is only related to kinds of refrigerants and suction pressure.

$$\varepsilon = \frac{v_{2'}}{v_{9'}} \quad (4)$$

$$\frac{P_{2'}}{P_{9'}} = (\eta_v \varepsilon)^k \quad (5)$$

$$\frac{T_{2'}}{T_{9'}} = \left(\frac{P_{2'}}{P_{9'}} \right)^{\frac{k-1}{k}} \quad (6)$$

where ε is the volume ratio of the compressor, k – the polytropic index of the compression process, η_v – the volumetric efficiency of the compressor, $P_{2'}$, [Pa] – the discharge pressure of the compressor, $P_{9'}$, [Pa] – the suction pressure of the compressor, $T_{2'}$, [°C] – the discharge port temperature of the compressor, and $T_{9'}$, [°C] – the suction temperature of the compressor.

The performance parameters

When the unit is running stable, the main performance parameters can be calculated according to the calculation model.

The heating capacity is given by:

$$Q = m_3 (h_{2'} - h_5) \quad (7)$$

The compression work is given by:

$$w_{9'-2'} = m_3 (h_{2'} - h_{9'}) \quad (8)$$

The COP is given by:

$$COP = \frac{Q}{w_{g1-2}} \quad (9)$$

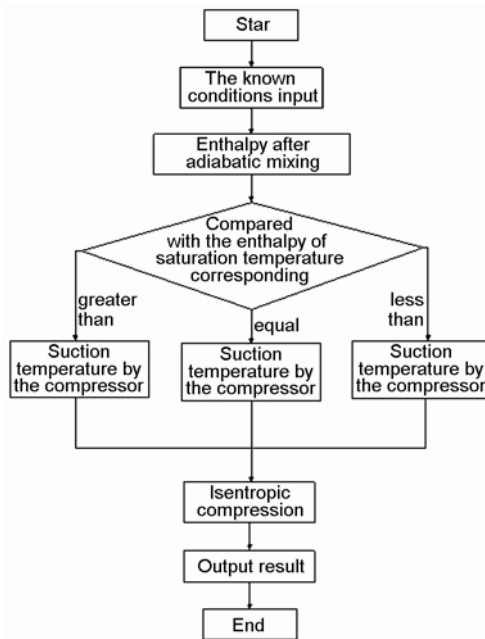

Figure 3. Flow chart of the calculation loop for the low pressure gas injection scroll compressor

Table 1. Main performance parameters temperature

Speed range [r minutes ⁻¹]	2000~9000
The suction volume [cm ³]	27
Maximum discharge pressure [MPa]	2.9
Maximum discharge temperature [°C]	120
Refrigerant	R134a

the sub-cooling degree of condenser's outlet 5 °C. The results of numerical analysis are compared with the experimental data in figs. 4-7.

Compressor discharge temperature gradually reduces with the decrease of the evaporating temperature (fig. 4). This is the consequence of the fact that compensation circulation through the intermediate heat exchanger into the suction cavity of compressor of the system investigated, is an adiabatic throttling process. The compressor power consumption and the heating capacity gradually reduce with the decrease of the evaporating temperature (figs. 5 and 6). The reason is lower suction pressure of the compressor for lower evaporating temperatures. Specific volume of the refrigerant is increased, and the compressor gas flow rate and the refrigerant flow rate are reduced, causing decreasing of compressor power consumption and

The calculation process of low pressure gas-injection scroll compressor

In suction cavity of the scroll compressor, the refrigerant mixing time is extremely short, it can be considered as an adiabatic isobaric enthalpy increasing process, and the temperature of refrigerant can be inversely calculated by the enthalpy of blended. Namely, it is the compressors suction temperature. There are two-phase states: saturation state, and overheating state of refrigerant after gas mixing, the kind of the state can be concluded by compare the refrigerant enthalpy after mixing with the enthalpy of the refrigerants' saturated temperature which is corresponding its pressure, then the compressors suction temperature obtained to do compress calculate. The specific process is shown in fig. 3.

Simulation and performance analysis

In this paper, we set a factory production of scroll compressor as an example, and we make a simulated calculation for the type of gas mixing heat pump air conditioning system. The main performance parameters of compressor are shown in tab. 1.

Parameters used in numerical analysis are: the condensing temperature 45 °C in winter heating mode; the evaporating temperatures -10 °C, -5 °C, 0 °C, and 5 °C;

heating capacity. Since, reduce rate of the heating capacity is greater than the reduction of the compressor power consumption energy efficiency ratio (EER) of the system is gradually reduces with the decrease of the evaporating temperature (fig. 7).

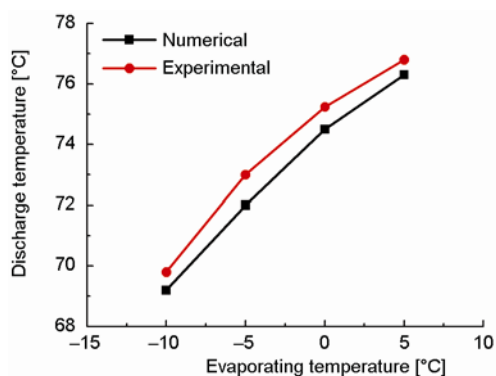

Figure 4. Variation of discharge temperature with evaporating temperature

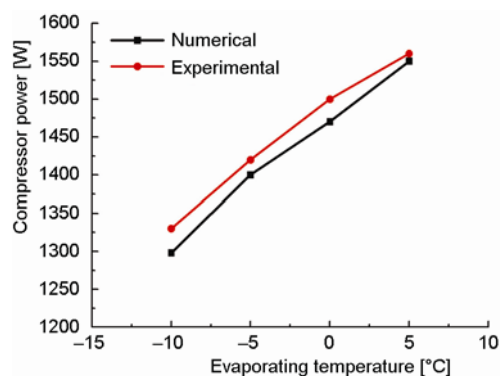

Figure 5. Variation of compressor power consumption with evaporating temperature

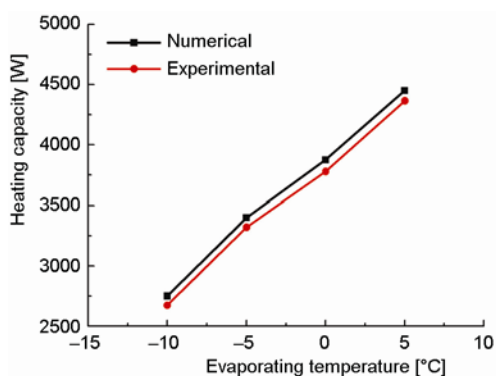

Figure 6. Variation of heating capacity with evaporating temperature

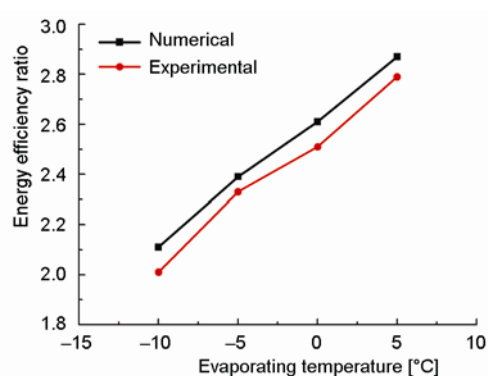

Figure 7. Variation of system EER with evaporating temperature

When the systems performance parameters changed with the evaporating temperature, the trends of simulated calculation value and experimental data are basically identical; the error of less than 5% between them belongs to the acceptable range; consequently, the model of the low pressure gas injection type of scroll compressor is basically applicable. The main reason for the error is that the gas mixing process is considered as an ideal-adiabatic process, ignoring the dissipative losses of pipeline. The compression process after gas mixing is regarded as an ideal-isentropic process, regardless of other influence factors including the clearance volume irreversible loss, the mechanical friction loss in the compressor during the experiment and the power consumption of the motor losses. In conclusion, multi-factor contributes to the error between the simulation calculation value and the experimental data.

Conclusions

Based on the basic thermodynamic circulation of scroll compressor, the first law of thermodynamics and the experimental data, the mathematical model of low pressure gas-injection scroll compressor is built. This paper not only has analyzed the dynamic characteris-

tics of the system and the performance of the compressor but also validated the simulated values by the experimental results; the maximum error of them is less than 5%. Therefore, the model is better to predict the performance of system.

References

- [1] Li, H. J., *et al.*, Heat Pump Air Conditioning System for Pure Electric Vehicle at Ultra-Low Temperature, *Thermal Science*, 18 (2014), 5, pp.1655-1660
- [2] Zhang, K., *et al.*, Mathematical Mode Research on Scroll Compressor System with Economizer and Performance Analysis (in Chinese), *Cryogenics & Superconductivity*, 37 (2009), 5, pp. 52-56
- [3] Pang, W. G., *et al.*, Study on the Running Characteristics of Air Source Heat Pump in Cold Area (in Chinese), *Heating, Ventilation and Air Conditioning (HVAC)*, 38 (2008), 10, pp. 82-85
- [4] Zhao, H. X., *et al.*, Thermodynamic Analysis for Heat Pump System with Economizer Coupled with Scroll Compressor (in Chinese), *Proceedings, Chinese Association of Refrigeration on Refrigeration and Air Conditioning Academic Conference*, 2005, pp. 543-549