

PROPOSAL OF CRACK PROPAGATION CONDITION CRITERION CONSIDERED CONSTRAINT EFFECT UNDER EXTREMELY LOW CYCLE FATIGUE; EVALUATION BY 1T-CT AND 2T-CT SPECIMEN

Y.KISHI¹, Y.WADA²

¹Kindai University
Higashi-Osaka, Osaka, Japan
kishi.yuto0714@kindai.ac.jp

²Kindai University
Higashi-Osaka, Osaka, Japan
wada@mech.kindai.ac.jp

Key words: Extremely low cycle fatigue, Finite element analysis, Constraint effect, Fracture criterion, Stress triaxiality, Equivalent plastic strain increment

Abstract. *The strength evaluation of structures that requires high reliability, such as power generation facilities, is extremely important. It is necessary to ensure safety under extremely low cycle fatigue caused by earthquakes. However, a highly reliable evaluation method has not yet been developed because of variable fracture toughness due to the constraint effect with large deformation. The crack propagation criterion proposed by the previous study has needed some modification for accurate prediction. In this study, we confirmed whether the crack propagation criterion proposed by previous study can reproduce the fracture behavior of the experiment. Among them, relationship between the number of cycle and crack length, hysteresis loop, reproduction of crack shape were evaluation items.*

1 INTRODUCTION

Accidents due to fracture is occupied by fatigue 80% of the total [1]. Therefore, to understand unstable fatigue fracture mechanism is important to ensure reliability of structure. In case of high cycle fatigue, stress intensity factor range exists as a fracture parameter which can predict crack propagation. However, crack propagation of materials under extremely low cycle fatigue caused by earthquakes, the fracture toughness differs due to the constraint effect with large deformation. Therefore, a highly reliable evaluation method has not yet been developed under extremely low cycle fatigue. For that reason, the cost of maintenance and management of nuclear power generation facilities is high because they are designed considering an excessive safety factor.

In the previous study[2], crack propagation criterion is proposed by Equation 1.1.

$$F_{elcf} = \Delta\varepsilon_{eq}^m + A(\delta/a_0)\sigma_{tri}^{1-m} \geq B(a/a_0) - C \quad (1.1)$$

where F_{elcf} is the crack propagation criterion, $\Delta\varepsilon_{\text{eq}}$ is the equivalent plastic strain increment, σ_{tri} is the stress triaxiality, δ is the load-line displacement, a/a_0 is the dimensionless parameter of crack propagation and A, B, C, m is the constant. Equation 1.1 is confirmed validity under restrict condition [2]. However, it is not considered constraint effect such as thickness and material properties. The objective of this study is confirmed whether or not Equation 1.1 can apply changing of constraint effect. Furthermore, we propose the crack propagation criterion considered constraint effect under extremely low cycle fatigue.

2 EXPERIMENT AND NUMERICAL ANALYSIS

2.1 Finite element model

In the previous study, it was used 1T-CT specimen of SUS316. Here, 1T means that thickness is 1 inch. In this study, we target at fatigue crack propagation experiment which were carried out by 2T-CT and 1T-CT specimen of SGV410 which are used in reactor piping. We extracted the experiment data from the reference[3]. Experiment conditions shows in Table.2.1.1.

Table.2.1.1 Experiment conditions

	R	ΔP [kN]	a_0 [mm]	a_f [mm]	N_f [cycles]
1T-CT	-1.0	28 ($0.7P_{\text{max}}$)	29.80	38.70	22
2T-CT		104 ($0.8P_{\text{max}}$)	61.65	75.43	19

Where, R is the stress ratio and $R = -1.0$ is a perfect double-swing experiment. The load amplitude is $\Delta P = 0.8P_{\text{max}}$ for 2T-CT specimen and $\Delta P = 0.7P_{\text{max}}$ for 1T-CT specimen. Here, P_{max} is the maximum load at a monotonic tension experiment. a_0 and a_f are dimensions initial crack and final crack. N_f is the number of cycle at the fracture.

Dimensions of 2T-CT specimen and finite element model for analysis show in Fig.2.1.1 and Fig.2.1.2. CT specimen has a symmetry for thickness direction and load-line direction. Thus, finite element model was a quarter size considering the symmetry to decrease analysis cost. The position of obtaining load-line displacement and load and the position of loading forced displacement are the tip of the pin hole which is shaped at 45 degrees from the center of it. Added shape is not originally present in the specimen. So, if plastic deformation occurs this area during the analysis, it may be impossible to provide forced displacement precisely. Therefore, elastic material defines in this area. We conducted the local mesh of minimum mesh size 0.6mm at the crack propagation area to evaluate crack tip physical quantity in detail. From modeling degree of freedom point of view, mesh shape used tetrahedral secondary elements. The procedure is the same for 1T-CT specimens.

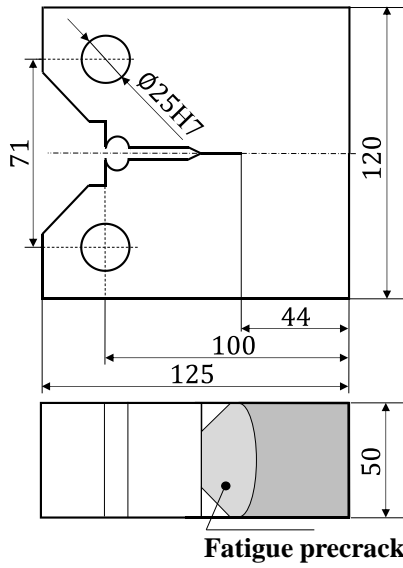

Fig.2.1.1 The dimension of compact tension specimen (2T-CT)

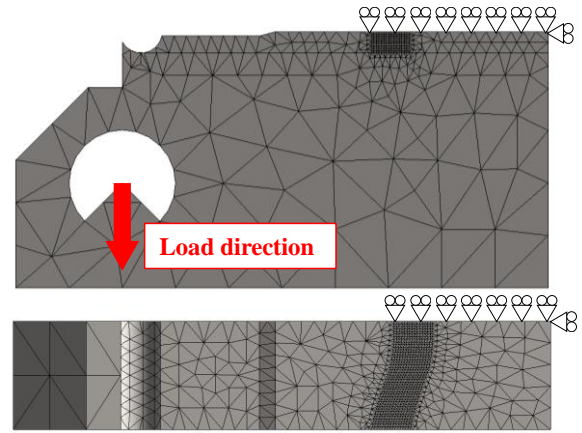

Fig.2.1.2 Finite element model of a quarter size compact tension specimen (2T-CT)

2.2 Generation phase analysis

Generation phase analysis means reproduction of experiment behavior by determining crack propagation timing and boundary conditions based on the experiment result. To perform this analysis, we need to conduct determination of stress-strain relationship and crack propagation timing.

Stress-strain relationship used in this study applied combined hardening rule to be determined by combining isotropic hardening rule and kinematic hardening rule. Isotropic hardening rule reproduces work hardening. Kinematic hardening rule reproduces Bauschinger effect. When we use combined hardening rule, it was decided based on true stress-true strain relationship of using material. True stress-true strain relationship of SGV410 shows in Fig.2.2.1. Isotropic hardening rule used n-th power hardening rule. Kinematic hardening rule used chaboche model shown in Equation 2.2.1.

$$\dot{\alpha}_k' = \frac{2}{3} \sum_{k=1}^m (C_k \varepsilon_k^{\text{eq}} - \gamma_k \alpha_k' \dot{\varepsilon}) \quad (2.2.1)$$

where, α_k' is the back stress increment, m is the number of back stress component, $\varepsilon_k^{\text{eq}}$ is the plastic strain increment, $\dot{\varepsilon}$ is the accumulation equivalent plastic strain increment, C_k, γ_k is the material constant. We decided this material constant using the relationship between true stress and true strain. However, this method is not standardized clearly due to rely on experience.

Crack propagation timing used the nodal force release method. In this study, the nodes corresponding to one row of crack tips were released together. First, we extracted the maximum and minimum value of load-line displacement in each number of cycle from the experiment data. Second, we made a graph of relationship between load-line displacement

and number of steps shown in Fig.2.2.2. Number of steps were decided based on displacement increment in analysis. Finally, the load-line displacement corresponding to the crack length for the minimum element size was determined from the relationship between load-line displacement and crack length. Its load-line displacement shows red plot in Fig.2.2.2. In the above procedure, we found number of steps at the time of crack propagation.

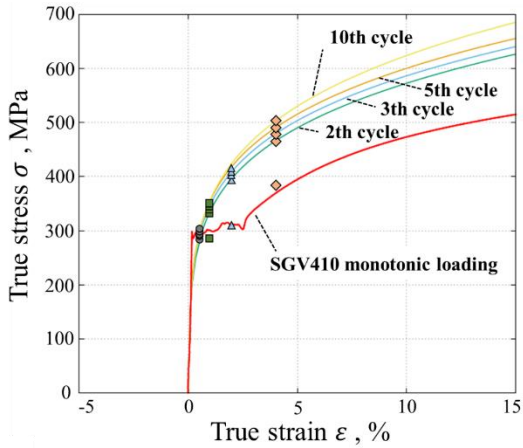

Fig.2.2.1 Relationship between true stress and true strain of SGV410

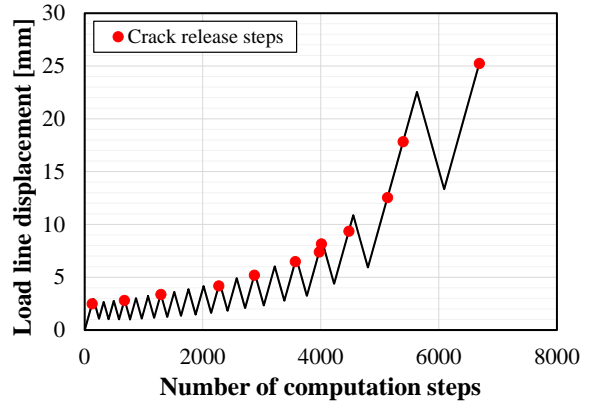

Fig.2.2.2 Crack propagation condition for finite element analysis based on experimental result

2.3 Application phase analysis

Application phase analysis changed the crack propagation timing to Equation 1.1. Equation 1.1 judged crack propagation if the value of F_{elcf} evaluated the analysis exceed the critical value depending on the crack length. When the value of F_{elcf} calculated using the integral average value of physical quantity which obtained the three main node from $M(X + 1, Z)$ to $M(X + 3, Z)$ shown in Fig.2.3.1 satisfied the condition as previously stated, displacement constraint of the main node $M(X - 1, Z)$ and the intermediate node next to it were released.

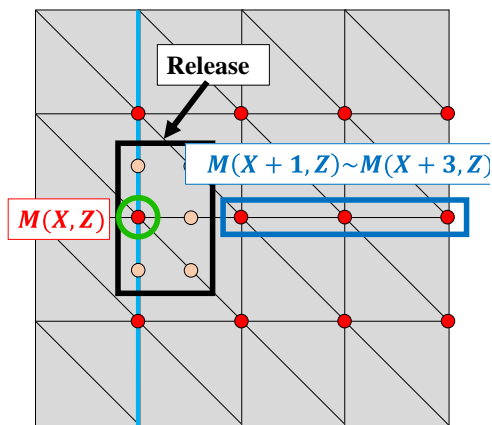

Fig.2.3.1 Nodal release method of application phase analysis

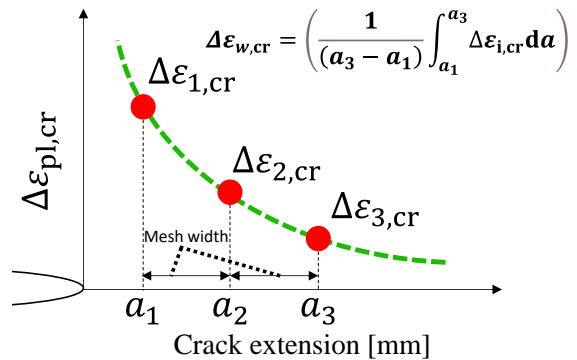

Fig.2.3.2 Calculate method of integral average

3 RESULTS OF GENERAION PHASE ANALYSIS (2T-CT SPECIMEN)

3.1 Hysteresis loop

Comparison with the relationship of load and load-line displacement between the experiment data and generation phase analysis shows in Fig.3.1.1. In the tensile process, there are the parts decreasing load temporarily. This means that the displacement constraints are properly released for each row. Overall inclination of hysteresis loop was match, so analysis accuracy was satisfactory. Accordingly, we obtained the crack tip physical quantities.

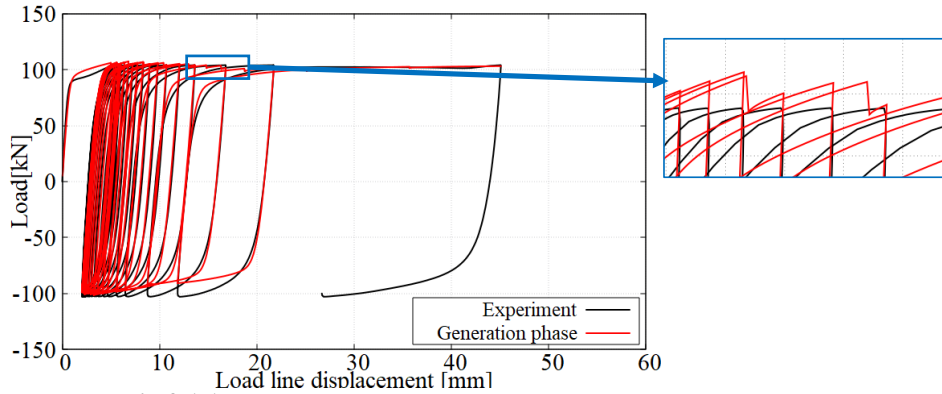

Fig.3.1.1 The relationship between load and load-line displacement

3.2 Physical quantities of σ_{tri} and ϵ_{eq}

Thickness direction distribution of stress triaxiality and equivalent plastic strain shows in Fig.3.2.1. In this graph, horizontal axis shows the thickness center side is 0 and thickness surface side is 25. The legend shows current crack length minus initial crack length, i.e. it shows the crack propagation quantity. Crack tip physical quantities are the critical value to obtain it in just before crack release. From Fig.3.2.1 (a), stress triaxiality tend to decrease as it approach the surface side. This inclination is the same holds for CT specimen of different thicknesses. From Fig.3.2.1 (b), equivalent plastic strain exists the peak in the thickness center and the center of analysis model. We conducted setup of the crack propagation condition criterion using these results.

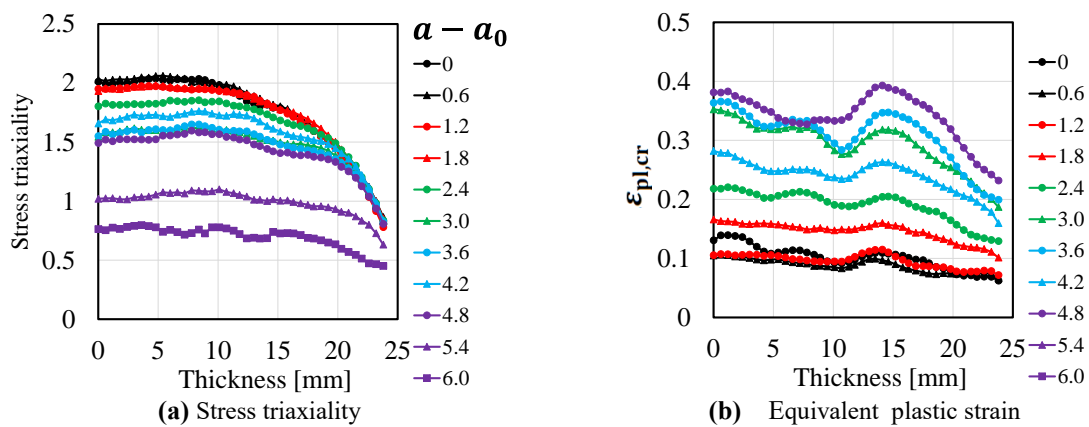

Fig.3.2.1 Thickness direction distribution

3.3 Setup of the crack propagation condition criterion

We calculated F_{elcf} using the result in Fig.3.2.1. F_{elcf} was calculated left side of Equation 1.1 including constant A . After that, we made a graph shown in Fig.3.3.1 using the relationship between F_{elcf} and a/a_0 . The plot of this graph was subjected to linear regression to obtain the constants B and C . Fig.3.3.1 is the thickness center data, but we obtained constants B and C in the nodes from thickness center to spaced 6 mm apart similarly. This result shows in Fig.3.3.2. Constants B and C tend to decrease as it approach the surface side, however its subtraction is constant. Accordingly, the value of thickness center which is the biggest in right-hand side including constants B and C was adopted.

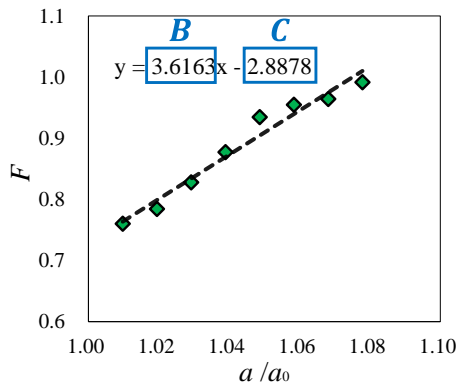

Fig.3.3.1 The relationship between F_{elcf} and a/a_0

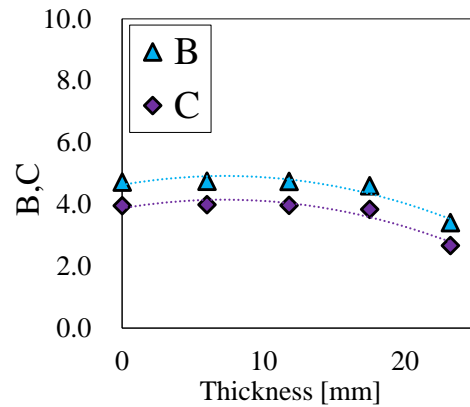

Fig.3.3.2 Thickness direction distribution of B and C

4 RESULTS AND DISCUSSION OF APPLICATION PHASE ANALYSIS

4.1 2T-CT specimen

The relationship between the crack length and number of cycle respectively obtained by application phase analysis, generation phase analysis and experiment shows in Fig.4.1.1. In the application phase analysis, there are multiple plots in one cycle because the crack length is calculated based on the ligament area with each constraint condition in the main nodes are released. Three results are similar inclination. Also the application phase analysis increases release counts as the final cycle approaches, so its release is faster than the others. This means safety side assessment, so Equation 1.1 is confirmed the validity in case of difference thickness and materials.

The crack shape in the final cycle shows in Fig.4.1.2. Displacement constraint was released rapidly in the center of analysis model. This inclination occurred the parts nearby the peak value in the thickness direction distribution of equivalent plastic strain. Therefore, reproduction of crack tunneling shape of center-advanced type is incomplete.

The value of left side and right-hand side in Equation 1.1 calculated when the condition was Fig.3.3.1 shows in Table.4.1.1. F_{elcf} is the addition value of left side and right-hand side, contribution of the left side i.e. equivalent plastic strain is high. From now on, we need to examine how it will change the crack shape and Fig.4.1.1 by adjusting this contribution.

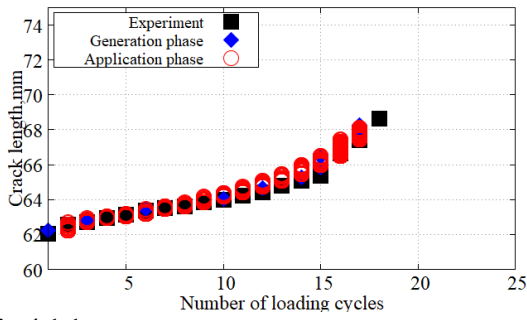

Fig.4.1.1 The relationship between a and N (2T-CT)

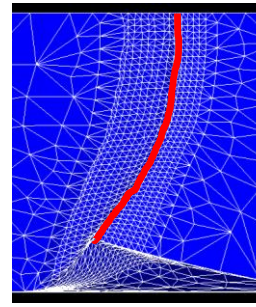

Fig.4.1.2 Crack shape in the final cycle (2T-CT)

Table.4.1.1 Left side and right-hand side in Equation 1.1 based on Fig3.3.1

a/a_0	Left side	Right-hand side
1.01	0.71	0.09
1.02	0.73	0.11
1.03	0.76	0.13
1.04	0.80	0.16
1.05	0.85	0.17
1.06	0.86	0.20

4.2 1T-CT specimen

We conducted generation phase analysis and application phase analysis similarly for the 1T-CT specimen. Generation phase analysis result in 1T-CT specimen abbreviate description because we get the good analysis accuracy likewise 2T-CT specimen. The relationship between the crack length and number of cycle respectively obtained by application phase analysis, generation phase analysis and experiment results are shown in Fig.4.2.1. The crack propagation in application phase analysis is slower than the others. So it indicates non-conservative side assessment.

The crack shape in the final cycle shows in Fig.4.2.2. Displacement constraint mostly was not released in the center of thickness. This area occurs shear lips in the original experiment. However, if we model shear lips, analysis costs increase because mesh division is complicated. Therefore, shear lips are not adopted in analysis model. From now on, the area which occurs the shear lips are not applied Equation 1.1. We consider to need if the node at its boundary satisfies Equation 1.1, the node from it to surface side are released all at once.

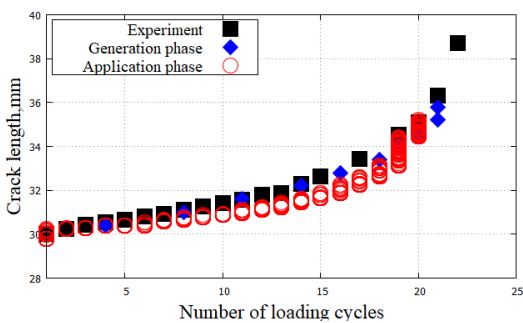

Fig.4.2.1 Relationship between a and N (1T-CT)

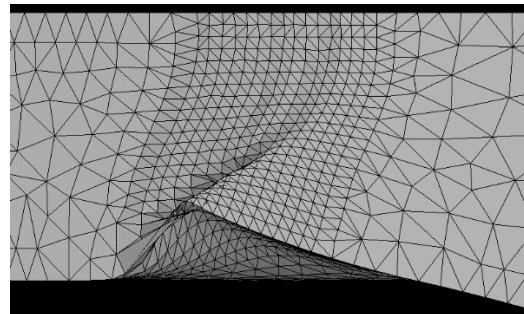

Fig.4.2.2 Crack shape in the final cycle (1T-CT)

5 CONCLUSIONS

We'd like to discuss the crack propagation criterion in the previous study was confirmed validity in different case of thickness and material. However, the reproduction of crack shape is incomplete. In the next work, we'd like to confirm validity in case of change the material, specimen, thickness and crack shape. Material uses AL2024-T3. We prepare three types of thicknesses: 5, 10 and 15mm. According to the analysis result, crack propagation condition criterion will be modified appropriately.

REFERENCES

- [1] Jono, M. and Ikai, Y. Fatigue of Advanced Materials. *J.soc Mat. Sci., Japan* (1994) **43** No.488: 587.
- [2] Y, Wada. and K, Ueda. Investigation of Fracture Criteria for Crack Propagation under Very Low Cycle Fatigue. *The 3rd International Conference on COMPSAFE* (2020)
- [3] Japan Welding Engineering Society, Atomic Energy Research Committee, MDF Subcommittee, Research on Ductile Fracture under Multi-Axial State of Stress for Component and Structure of Light Water Reactor, (2018) **195, 210, 232, 233**